

# JTL 68.4 - 4,0 ton

Tower TA 10.3 2-fall rope

## Topless Luffing crane

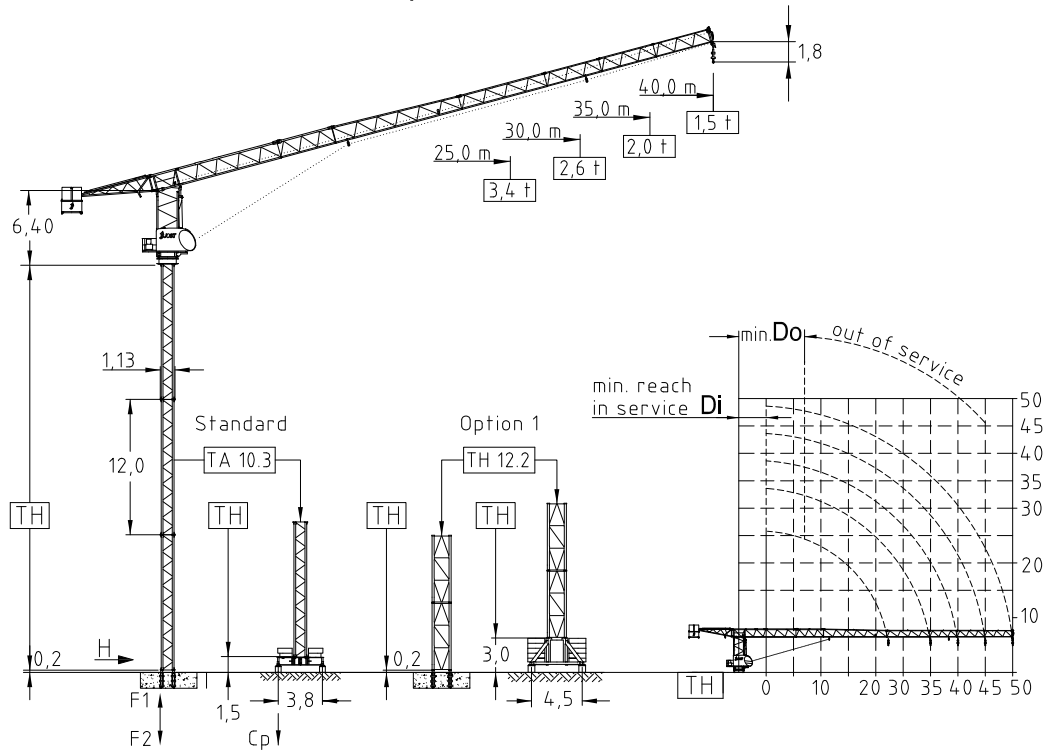

Jib (m)	Jib reach (m)		Tower heights all data in (m)			
			Standard Tower		Option 1	
			Foundat.	Chassis	Foundat.	Chassis
	Di	Do	TH 10.3	FC 3,8-10.3	TH 12.2	UC 4,5-12.2
25,0	3,5	10,0	33,0	30,0	36,0	33,0
30,0	3,5	10,0	30,0	27,0	33,0	30,0
35,0	3,5	9,0	27,0	24,0	33,0	27,0
40,0	3,5	9,0	27,0	21,0	30,0	27,0

EN 14439 : 2008  
WIND C 25  
ISO 9001 : 2008



Radius & Capacity											
Jib		max. Load	Jib reach								
m	rope		t	m	15	18	20	22	25	30	35
40,0	⊗	4,0	15,9	4,00	3,52	3,15	2,85	2,49	2,05	1,74	1,50
35,0	⊗	4,0	18,2	4,00	4,00	3,62	3,28	2,86	2,36	2,00	
30,0	⊗	4,0	19,9	4,00	4,00	3,98	3,60	3,15	2,60		
25,0	⊗	4,0	21,4	4,00	4,00	4,00	3,89	3,40			

Hoist 22,0 kW FI							
⊗	t	1,2	1,8	2,8	4,0	4,0	4,0
	m/min	15	26	31	41	51	62
Drum capacity							280,0 m

Hoist 30,0 kW FI							
⊗	t	0,7	1,0	1,6	2,4	3,0	3,0
	m/min	124	114	90	68	58	32
Drum capacity							580,0 m

Power requirement  
400V (±10%) - 50Hz

Motor	7,5 kW FI	1 x 2,0 kW	2 x 3,0 kW
t/v	2,0 min	0,77 rpm	25,0 m/min
Power requirement		Hoist 22,0 kW	45 kVA
Upper part		Hoist 30,0 kW	55 kVA

Shipping		
	Truck	Cont.
Top crane	4	5
Tower 2 unit	1	1
Climbing	1	1
Chasis	1	1

Counter weight	
Block 1	3 x 4,0 t
Block 2	1 x 1,0 t
Total	13,0 t

Ropes		
	D (mm)	N/mm <sup>2</sup>
Hoist	12,0	1960

# Climbing

External  
Internal  
(example only)

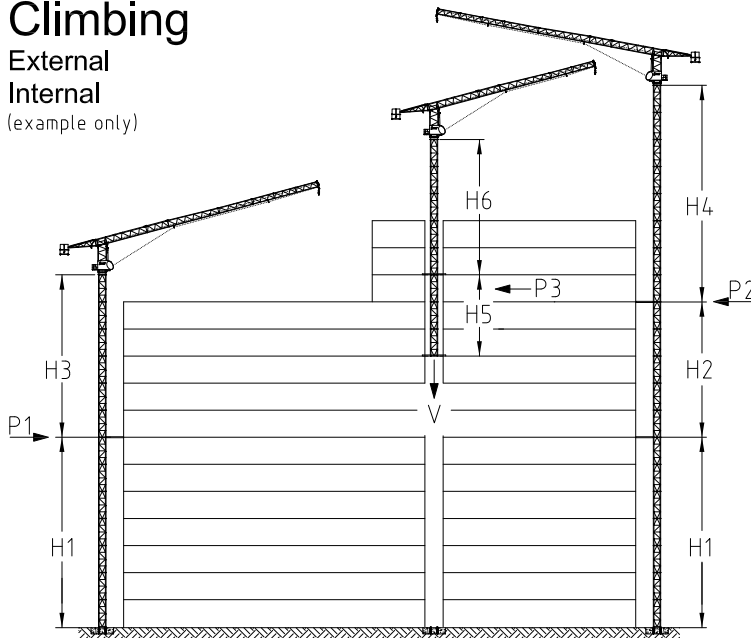

	m	in service	out of service
		t	t
H1	30,0		
H2	18,0		
H3	24,0		
H4	24,0		
H5	14,0		
H6	21,0		
A	2,00		
B	1,60		
P1		63,0	239,3
P2		78,1	238,3
P3		93,1	269,3
V		425,4	375,4

All data with TH 12.2

Jib length 25,0 m

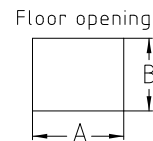

## Assembly sequence TA 10.3

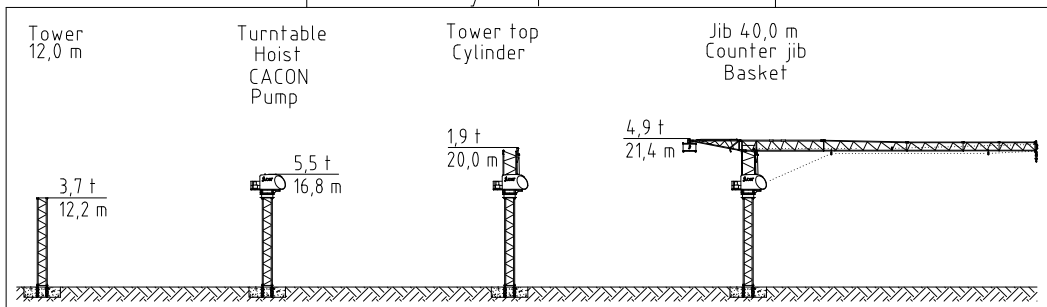

## Crane on foundation plate

Jib length (m)	Tower height (m)	No. of Towers	Foundation loadings			Corner forces	
			M (kNm)	V (kN)	H (kN)	F1 (kN)	F2 (kN)
40,0	27,0	4,5	2846,0	327,1	93,5	1853,0	- 2016,0
35,0	30,0	5,0	2904,0	348,1	91,9	1918,0	- 2092,0
30,0	30,0	5,0	2947,0	327,9	92,1	1962,0	- 2126,0
25,0	33,0	5,5	2741,0	325,9	88,3	1730,0	- 1892,0

## Crane on chassis

Jib length (m)	Tower height incl. chassis (m)	No. of Towers	in service		out of service		Ballast (t)
			Cp (kN)	H (kN)	Cp (kN)	H (kN)	
40,0	21,0	3,5	547,0	25,6	856,0	93,5	65,0
35,0	24,0	4,0	584,0	25,4	879,0	96,6	75,0
30,0	27,0	4,5	614,0	24,2	901,0	96,7	85,0
25,0	30,0	5,0	613,0	22,9	904,0	96,9	90,0

## Part list

Part	L (m)	W (m)	H (m)	kg	Part	L (m)	W (m)	H (m)	kg
Jib 01	11,29	0,94	1,54	1785	Hoist unit & rope	1,39	1,85	0,60	820
Jib 02	8,02	0,90	1,32	800	Turn table+slew.unit	2,15	1,80	1,85	2820
Jib 03	11,79	0,90	1,30	810	Tower top	5,50	0,96	1,80	1265
Jib 04	5,15	0,90	1,06	270	CACON & hydraulic	4,35	1,50	2,60	1600
Jib 05	5,12	0,90	1,05	195	Ballast basket	1,76	2,04	1,64	430
Jib 06	5,11	0,90	1,04	165	Hook block	0,82	0,35	1,10	140
Jib end	1,38	0,90	0,90	140					